

INT

Devilink™ HR – Hidden Relay Installation Manual

DEVI ™
Member of the Danfoss Group

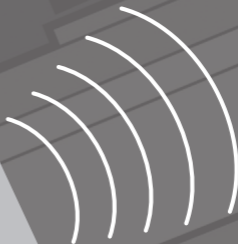

Devilink™ HR

The Devilink™ HR (Hidden Relay) is a device for switching heating elements or other electrical equipments ON/OFF, either manually or by schedule.

Installation scenario:

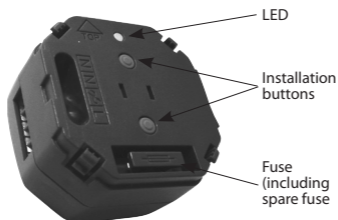
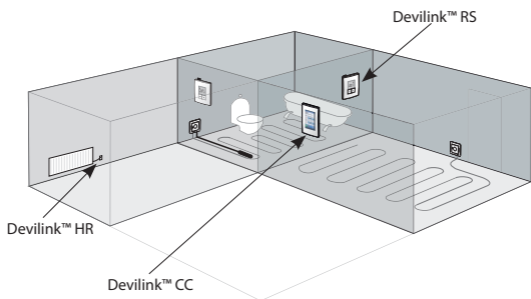

Placement of Devilink™ HR

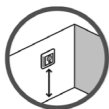

Installation and placement must be according to local building regulations.



Operation modes

Devilink™ HR supports two types of operation modes.

1. Heating regulation
2. On/OFF switching

When using Devilink HR as heating regulation you also have to install a Devilink RS and consider the following advices for controlling the heating.

Do not install floor heating system without a floor sensor when the heating element is installed on or beneath wooden surfaces and other surfaces sensitive to temperature!

Installation of Devilink™ HR

Installation of Devilink™ HR

1. Devilink™ HR is to be mounted in to a build in box in the wall.

It is recommendable not to install the HR in a metal box due to the disturbing of the signals of the system.



2. Installation of the Devilink™ HR according to the connection diagram.

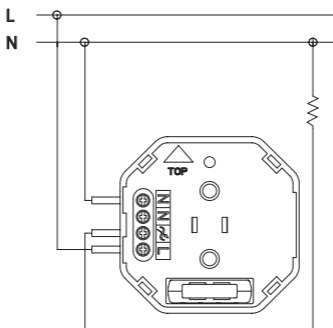

Configuration:

See Step-by-Step guide in Devilink™ CC instruction manual.

Trouble shooting

Green LED ON	Relay ON
Red LED ON	Relay OFF
Green LED fast flash	Inclusion or link test
Red LED short flash	Inclusion not OK, goes to not included. Linktest not OK, goes to missing link

Factory reset of Devilink™ HR

By holding both buttons in front of device for approx. 5 sec. until LED gives a red flash – the unit is reset to factory setting.

Note:

If the fuse is burned you can find a spare by pulling open the tap and replacing the burned fuse with the spare located immediately above the burned fuse.

Disposal Instruction



Technical specifications

Operation voltage	230 V AC, 50 Hz
Standby consumption	<1W
Load	2300 W, 460 VA, 600 W Incandescent Bulbs
Regulation	PWM
Ambient temperature	0° to +35°C
Micro-fuse	T 10 A H
Transmission frequency	868.42 MHz
Transmission range in normal buildings	Up to 30 m
Transmission power	Max. 1 mW
IP class	20
Dimensions	52 mm × 52 mm × 31 mm

The 2 Year DEVI Warranty

You have purchased a DEVI heating system which we are sure will serve to improve the comfort and economy of your application.

DEVI provides superior electrical heating solutions for total climate control in and around homes and buildings. DEVI offers a complete product program with Deviflex™ heating cables or Devimat™ heating mats, Devireg™ thermostats, Devifast™ fixing strips and Devi Self-limiting heating cables combined with additional products completing the product program.

This 2 year warranty applies to all DEVI products.

Should you, against all expectations, experience a problem with your DEVI product, you will find that DEVI offers a 2 year warranty from the date of purchase on the following conditions:

During the warranty period DEVI shall offer a new comparable product or repair the product in case the product is found to be faulty by reason of defective design, materials or workmanship. Repair or replacement shall be carried out at DEVI's discretion. DEVI shall not be liable for any consequential or incidental damages including, but not limited to, damages to property or extra utility expenses.

This warranty shall only be valid on production of proof of purchase and must be submitted to the installer or seller without undue delay.

An extension of the warranty period following repairs undertaken under warranty cannot be granted.

The DEVI Warranty shall not cover any damage caused by incorrect conditions of use, incorrect installation or if installation has been carried out by non-authorized electricians. All work will be invoiced in full if DEVI is required to inspect or repair faults that have arisen as a result of any of the above.

The DEVI Warranty shall not extend to equipment which has not been paid in full.

DEVI will, at all times, provide a rapid and effective response to all complaints and inquiries from our customers.

The warranty explicitly excludes all claims exceeding the above conditions.

The 2 Year DEVI Warranty

Warranty Certificate

The DEVI™ Warranty is granted to:

Name:

Address

City:

Country:

Telephone:

Attention:

The Warranty Certificate must be completed correctly for the Warranty to be valid.
Please read the Warranty conditions above.

Type of thermostat:

Electrical installation by:

Article number:

Date:

Suppliers Stamp:



Article No: 08095963

Version: 01.02

DEVI A/S

DK • 7100 Vejle

Phone +45 7488 8500

Fax +45 7488 8501

VIFRS102 © Danfoss 09/2009

